

tone dexter® II



User Guide

Software Version 4.0

User Guide Version 4.01



Warnings and Safety Notes

- Excessive sound levels from headphones can cause hearing loss.
- Choking hazard due to swallowing of small parts if unit is disassembled, especially for children.
- Properly dispose of any plastic covers and packaging to prevent choking hazard.
- ToneDexter II is intended to be used in private and public performance environments as an interface between stringed instruments and PAs/Studio Mixers/Analog to Digital Interfaces. Any other use, as well as use under other operating conditions, is considered improper use.
- Be aware of possible staining due to abrasion of the rubber feet.
- Do not use ToneDexter II outside in rainy conditions if there is a chance that the unit or power supply could become wet.
- Use the device with an adequate power supply. The supplied power supply has been chosen for its performance. [PSU requirements](#) are noted in this user guide together with info about TDII power connector polarity!
- There are no user serviceable parts inside and ToneDexter II operates internally on a low voltage of 9-15V external power supply. ToneDexter II does not contain any batteries.
- N. American units are supplied with a 120V power adaptor, outside N. America ToneDexter II is supplied with a power adaptor that has a selection of plug types. In both cases the power supply can be used from 110V-240V 50-60Hz mains.
- ToneDexter II is compliant with CISPR 32:2015 Class B, electromagnetic compatibility of multimedia equipment - emission requirements.

Packaging Materials Disposal

Disposal of cardboard and plastic packaging materials.



Packaging Materials Disposal France

Disposal of cardboard and plastic packaging materials.



Old ToneDexter II & PSU Disposal

These products must be sent to separate collection facilities for recovery and recycling.

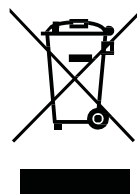

ToneDexter II & PSU No Batteries

These products do not contain or use batteries.



Audio Sprockets, LLC

Nevada City, CA 95959 USA

Contents

Warnings and Safety Notes 2

A Word About Power Supplies 4

What Is ToneDexter II?..... 5

Introduction 6

Connectivity 6

Front and Side Features 7

Rear Features 8

Quick Start Basics 9

Training Procedure10

Definition of Terms13

Operating Modes.....14

Play 14

Mute/Tune 14

Boost 14

Bypass 15

Footscroll..... 15

Train..... 15

Audition..... 15

Record/Playback..... 16

Configuration Controls17

Main Page – Inputs..... 17

Main Page – Outputs..... 18

Aux source options 18

FX Send source options..... 18

Out and DI source options..... 18

Signal Routing Diagram 19

Main Page – Feature Tabs 20

EQ Tab 20

High band filter 20

Mid band filter 20

High pass filter 20

Low band filter 20

Anti-Feedback 21

Spaciousness 22

Notch Tab 22

Notch filter 22

Reverb Tab..... 23

Compressor Tab..... 24

Main Page – WaveMap 25

Rename WaveMap..... 25

Manage WaveMap 26

Baking WaveMaps 26

Morphing WaveMaps 27

System Config Settings 28

Footscroll..... 28

Screenlock 29

Display Settings 29

MIDI Setup..... 30

Advanced..... 31

Active and Baseline Memory 32

Using the Web Interface..... 33

Managing WaveMaps 33

Color and Text Meaning 34

Backup Button 35

Restore Button..... 35

Help Button 35

Updating Software 36

| | | | |
|-----------------------------------|----|------------------------------|----|
| <i>Recovery method</i> | 36 | Pro Tips | 39 |
| Integrating a Looper | 37 | System Diagram | 40 |
| Troubleshooting Info | 38 | Technical Specs | 41 |
| Factory Reset | 39 | | |

A Word About Power Supplies

ToneDexter II ships with a 12V power supply rated either 700mA (8.4W) in the US or Canada, or 1A (12W) for Europe. The one for Europe comes with adaptor blades for a variety of countries. Both have universal input and can work with mains voltage of 100V-240V, 50-60Hz.

ToneDexter requires more peak power to start up than continuous power to run. 3rd Party Power supplies are rated differently, some conservatively, some optimistically. Some have more peak starting power available than others.

To account for the extra current needed during startup, the minimum recommended power supply ratings are shown in the table below. Some supplies with lower ratings may work.

| | Units with serial numbers ASxxxxxx0001 – ASxxxxxx1000 | | Units with serial numbers ASxxxxxx1001 and higher | |
|----------------|--|-------|--|-------|
| Output Voltage | Minimum Recommended Current Rating | Power | Minimum Recommended Current Rating | Power |
| 9V | 900mA | 8.1 W | 670mA | 6.0 W |
| 12V | 675mA | 8.1 W | 500mA | 6.0 W |
| 15V | 540mA | 8.1 W | 400mA | 6.0 W |

If you are experiencing issues like the screen going white, the unit continuously resetting at startup, or working some of the time but not at other times, it is most likely because the power supply you are using is underpowered.

The good news is that most pedal board power supplies have multiple floating outputs, and you can usually get enough power by using a current doubling (parallel) daisy-chain cable connecting two outputs (with the same rating) together to feed ToneDexter II.

If you want to run your unit from **battery power**, there are many 12V rechargeable lithium-ion packs available with ratings from 3000mAh to more than 10000mAh. Divide the rating by the 12V figures in the table to estimate how long it will power ToneDexter before recharging.

What Is ToneDexter II?

ToneDexter II is an innovative professional grade preamp that improves the sound of an acoustic instrument pickup.

With a simple training process, it learns the difference between how an instrument sounds through a microphone and how it sounds through its pickup.

Using proprietary WaveMap® technology, it corrects the pickup so that it sounds like the mic.

A WaveMap is a configurable set of parameters that contains an enhanced resolution impulse response (IR), EQ, tone shaping, reverb, compression, level, routing, and other information.

It stores up to 32 WaveMaps at a time which can be used for different sound variations of the same instrument, or different instruments, or even different routing configurations for inputs and outputs.



Introduction

How To Use This Guide

Once you have a sense of what the controls do, go to [Quick Start Basics](#) and then [Training Procedure](#) to jump right in and create a custom WaveMap for your instrument.

Look over the [Operating Modes](#), then familiarize yourself with the [Configuration Controls](#).

See [Troubleshooting Info](#) if you are having any problems.

Experiment Without Worry

Don't be afraid to tap buttons and turn controls to see what they do. You can always easily undo changes and go back to where you were.

If you get into a situation that would make a permanent change, such as deleting or overwriting a WaveMap, you will be warned and asked to confirm your choice.

ToneDexter II is designed to be fun and easy to use, so take a little time to play around with it without worry. In no time, you'll be an expert user!

Connectivity

Live

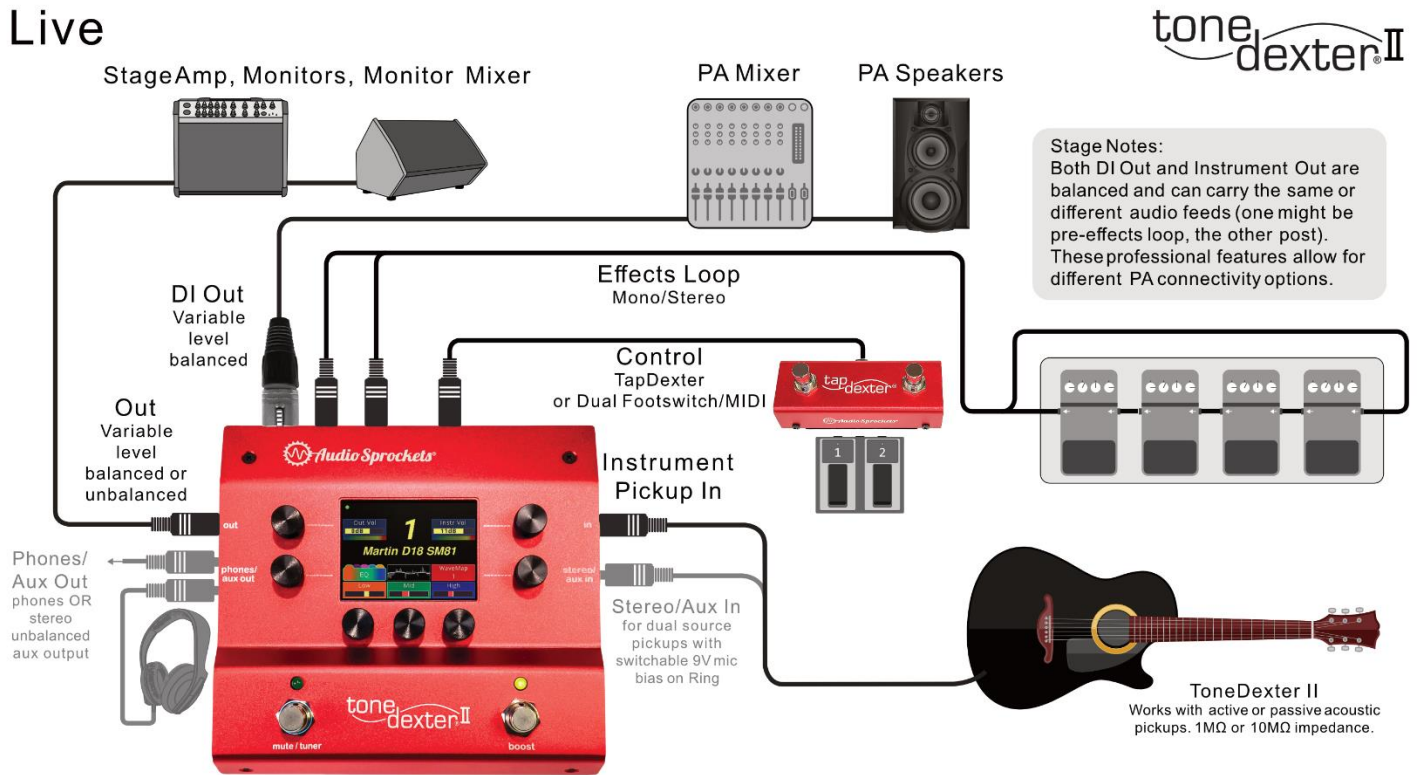

Front and Side Features



Output Controls

Adjust output level. Tap to set all output levels and routing.

Instrument Output

1/4" balanced or unbalanced mono. Source configurable.

Stereo Phones/Aux Out

1/4" balanced TRS. Drives headphones, or can be used as a stereo Auxiliary line output. Source configurable.

Feature Tab Selection

EQ, Tone Shaping, Notch, Reverb, and Compressor feature selection, determines which set of controls appears on main page

Selected Feature Controls

Adjustment controls for whichever feature tab is selected. Press a knob for detailed adjustments.

USB 2.0 Port

For software downloads and WaveMap management.

Mute/Tune/Scroll

Tap to Mute and Tune. Can also be used to select WaveMaps in Footscroll mode.

Color Display

Context driven content with minimal clutter.

Input Controls

Adjusts input gain. Tap to set all input levels and sources.

Instrument Input

1/4" mono phone jack. 1M Ω or 10M Ω impedance.

Stereo/Aux Input

1/4" TRS jack. Stereo input mode supports dual source pickups with switchable 9V mic bias on RING.

WaveMap Select and Edit

Select from 32 slots. Tap to manage WaveMaps

Boost/Train/Scroll

Tap to boost by 2-11dB. Also used to initiate training. Selects WaveMaps in Footscroll mode.

Rear Features

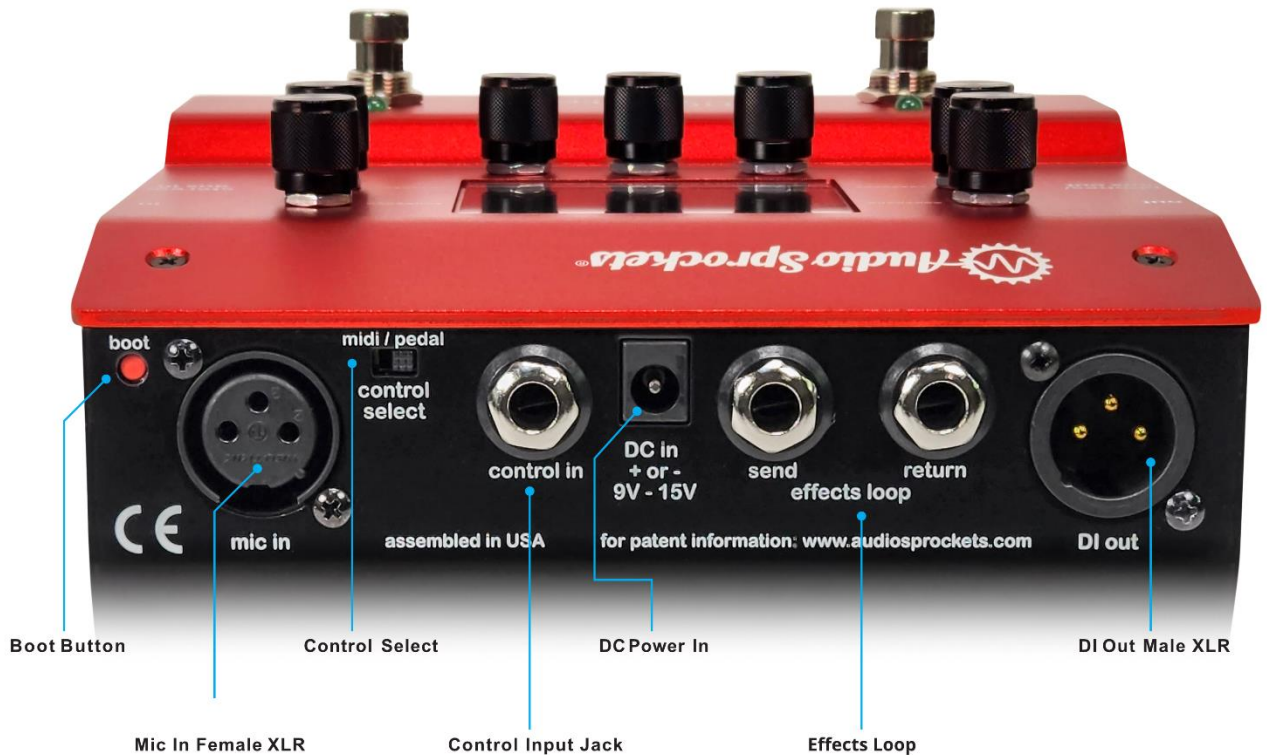

Boot button

Tap to reboot, (Hold initiates the recovery software update procedure – see [Updating Software](#)).

Mic In

XLR Female, with switchable 48V phantom power.

Control Select switch and Control Jack

Set to **Pedal** for external dual footswitch control.

Set to **Midi** for a standard TRS Type A MIDI connection to select WaveMaps with Program Change commands.

DC In

Accepts 9V to 15V DC power, either polarity.

Effects (FX) Send and Return

1/4" TRS jacks. Supports mono, stereo, and dual channel configurations.

DI Out

Balanced XLR, source configurable.

Quick Start Basics

Training

While ToneDexter II works as a great preamp right out of the box, to get the best sound it's necessary to create at least one custom WaveMap for your instrument by training ToneDexter II with a microphone.

Once that's done, the mic is no longer needed. Up to 32 WaveMaps can be stored in the unit at a time.

These can be for the same instrument with different mics or mic positions, or for different instruments.

ToneDexter II does not come pre-loaded with any existing WaveMaps because they would not work optimally for your particular instrument, pickup, and mic. However, training is easy so let's get started!

What You'll Need

- **ToneDexter II** with included power supply or suitable alternative.
- **Your instrument, fitted with a pickup.** Most active and passive piezo pickups will work. Magnetic pickups can work to some degree – it may make the sound 'more acoustic' – but will not achieve a realistic miked sound.
- **Microphone.** It doesn't need to be expensive. What works best for studio recording is not necessarily optimum for training as the requirements are different. See Helpful Training Info below and also the Audio Sprockets website for microphone guidance.
- **Microphone stand.** This is important so that whatever position you choose will be fixed and repeatable.
- **Headphones (optional).** Closed ear type preferable. This is useful to assess the sound as you position your microphone, and to compare results. If you don't have headphones, don't worry—you can still get great results

Training Procedure

Training

tone dexter II



1. Set up a mic on a stand and plug it into the Mic in jack.
2. Plug your instrument into either the Instrument or Aux jack. ToneDexter II will know which one you are connected to.

Helpful Tip: For standard mono pickups, you will normally just use the Instrument jack. If you are using a dual-source or stereo pickup, and you are plugged into the Aux jack, there will be an option on the training page to select from either Aux 1 or Aux 2. Aux 1 is the default if nothing is plugged into the instrument jack.

3. If you are using headphones to monitor the training process, plug them into Aux out.
4. **Tap Mute** to get to Tune mode if you are not there already.
5. **Tap Boost** to get into Train-Level Set mode. At this point, all outputs except Aux will be muted.
6. Once you position the mic, start playing at a medium loudness. ToneDexter II will automatically set the instrument and microphone gains to give you enough headroom to avoid distortion. You should see the level meters both be in the middle range.

Helpful Tip: Don't worry about precisely how loud you are playing, the resultant WaveMap will be at a fixed power level, independent of pickup and mic gains and of how loudly you play during training.

7. Once the levels are set, ToneDexter II will automatically proceed to Training mode. Play for about a minute as you hear the training in the headphones and watch the progress bar shown on the screen. **Tapping Boost** changes the sound routed to the headphones between WaveMap, pickup and microphone.

Helpful Tip: It doesn't need to be musical. What's important is that the instrument's character and overtones are excited. Furthermore, playing soft and loud doesn't help the training process. Play at a medium level, being careful not to move your position relative to the mic.

Recommended approaches:

- Guitar, mandolin, banjo, etc – open chords, open strings, barre chords up and down the neck to say 5th position or so. Fingerpicking or flat picking are both fine. Flat picking may train a little faster though. The resulting WaveMap will apply to any style of playing.
 - Violin, cello, double bass – double stops and string sweeps on open strings and higher. Bassists should ideally use a bow and not pizzicato, as arco best facilitates training. The resulting WaveMap will apply to any style of playing.
8. Once the training period completes, the WaveMap will be transferred to a holding position, awaiting confirmation as to which slot to store it in. Before deciding to keep it, you can tap Boost to audition the WaveMap, the raw pickup, and the live Mic sound for comparison. Brace yourself for a shock!
 9. You can name the WaveMap by either using the etch-a-sketch controls (Cursor and Char), or use a small temporary name for now and rename more conveniently later using the web interface.
 10. The next available empty slot will be selected automatically to save the new WaveMap, but you can select any other slot. If that slot is occupied it will be overwritten.
 11. **Hold Boost** to store the WaveMap.

Helpful Training Info

- If you stop playing, the training process will just wait for you to continue.
- To cancel out of training, **Tap Mute** or the **Back** button.
- Mic EQ can be adjusted during training by tapping Mic EQ. This will reset the training process back to the start to use the new EQ. The next time you train, the Mic EQ adjustments will be remembered, but the default will always be flat when you restart the unit.

- **Hold the Mic EQ button** to reset the Mic EQ to flat. Note that the mic high-pass filter cannot be turned all the way off during training as a minimum setting of 20Hz is required for the training process.
- You can store several WaveMaps using different mics and/or mic locations and decide later which ones to keep or to move to different locations.
- You can train in virtually any location—you don't need a refined acoustic space, since the WaveMap training picks up very little of the room sound. Small, tiled rooms are not recommended however.
- A small diaphragm condenser (capacitor) mic is recommended. Large diaphragm mics can also work well but may be more finicky about placement due to their response coloration.
- Dynamic mics such as common vocal mics, can yield good results though generally will not have as much high frequency information, and tend to be quite colored. However, that might just be the sound you're after!
- Tube (valve) mics, due to their high non-linearity, are not recommended but may yield good results nonetheless.
- Both cardioid and omni-directional pickup patterns will give excellent results. Using an Omni mic can often get a more balanced sound quicker.
- Ribbon mics may also be used. Passive ribbon mics may be used so long as they can tolerate 48V phantom power. If using a passive ribbon mic, consider either plugging in the mic first before powering up the unit, or first disabling 48V phantom power.

Helpful Tip: 48V phantom mic power is on by default. Red = ON, Gray=OFF. If you want to turn it off, **tap the symbol** on the **Train – Level Set page**, or in **System Config**.

- **A note about hum:** If you are using a passive piezo pickup, you may hear some AC power line buzz or hum if your system is not grounded. In normal use, ToneDexter II will be connected to an amplifier or PA system which is grounded (earthed), and you will not experience any noticeable hum.
- But if you do experience hum in your headphones when training, plugging one of the other outputs into a grounded system will eliminate it.

Definition of Terms

WaveMap - a configurable set of parameters that ToneDexter II creates, stores, and uses. It contains enhanced resolution impulse response (IR), EQ, tone shaping, reverb, compression, level, routing, and other information.

IR – an impulse response. A complex filter which maps the sound of your pickup to the sound of your mic.

Slot – one of 32 WaveMap storage locations.

Tap – a quick press and release to one of the footswitches or controls.

Hold – pressing and holding a footswitch or control for at least one second until the display changes or the action takes effect.

Mute – the left footswitch.

Boost – the right footswitch.

Control – a digital encoder knob for selecting values or options either by rotating or by a Tap or a Hold action.

TRS connector – a jack or mating plug that has 3 connections: TIP, RING, and SLEEVE (ground). Sometimes known as a stereo connector.

TIP – the main conductor in a TRS connector. This is the same as in a mono connector.

RING – the second conductor in a TRS connector, used to carry a signal for a second pickup, for example.

Frequency Response Plot – dB magnitude (loudness) is shown on the vertical axis as a function of the frequency on the horizontal axis.

Impulse Response Plot – The IR is shown with linear magnitude on the vertical axis as a function of time on the horizontal axis.

Instr – abbreviation for instrument input, labeled **IN** on the unit.

Aux1/Aux2 – the two inputs associated with the input jack labeled **aux in** on the unit.

Operating Modes

This section provides a summary of all the operating modes and how to use them.

Play

The default mode, it processes your pickup sound with a WaveMap IR and any EQ or Tone Shaping settings like Anti-Feedback or Spaciousness, as well as optional reverb or compression.

Input levels and input source selection are WaveMap-specific parameters and are automatically recalled as you change WaveMap.

Output and boost levels are system-global settings that stay fixed as you change WaveMaps.

FX and Output routing as well as tuner reference frequency are by default system-global settings, but may optionally be set to be WaveMap-specific by tapping the associated Sprocket. This turns it gold, and confirms the parameter is now WaveMap-specific.

Mute/Tune

Tap Mute to mute all outputs except Aux which can be configured to be muted as well, or alternately to hear the bypassed pickup signal while tuning.

A precision tuner is engaged, accurate to less than 1 cent.

Automatically tunes from whichever jack (Instrument or Aux) you are plugged into. If you have instruments plugged into both jacks, it tunes from whichever jack the WaveMap configuration has set as its input.

Display style and reference frequency can be adjusted.

Boost

Tapping Boost during Play Mode Increases the output level by a fixed 2-11dB, per your preference. Tapping again returns to normal level.

The boost level is configurable on the Outputs page.

Helpful Tip: *The extra gain provided is in the analog domain so as not to compromise digital headroom. If you already have the output level set very high, the full boost level may not be achievable. For example, if you want 8dB of boost, make sure the Output level is set to 6dB or less since 14dB is the maximum available.*

Bypass

Hold Mute to enter and exit Bypass mode. Audio is routed straight from the digital input to the digital output, bypassing all signal processing.

This function may be changed to engage Record/Play instead of Bypass. See Footscroll under System Config -> Advanced to configure.

Footscroll

Hold Boost to enter Footscroll mode*. In this mode, Boost and Mute increment and decrement the WaveMap selection number. To go between Play and Tune in this mode, Hold Mute. Hold Boost again to exit Footscroll mode.

*Provided you have configured footswitches to be Integral on the System Config page. External is the default. If you have configured footswitches to be external, this does not apply.

Train

Tap Boost from Tune mode to enter Train.

The first phase of Training is the Level Set phase. As you play, it will set instrument and mic gains to facilitate IR creation. This gain setting is retained for the saved WaveMap as the optimum for signal strength and headroom, but can always be adjusted later.

Training phase starts automatically after Level Set completes.

Tapping Boost cycles through audition Sources: Pickup, Mic, and WaveMap. The training process will continue while you do this.

Mic EQ can be adjusted to tailor your mic's sound. The training will then create a WaveMap to match the EQ'd mic sound.

Audition

Happens when training is complete, before you save the newly created WaveMap into a chosen slot.

Tapping Boost cycles through audition Sources: Pickup, Mic and WaveMap.

You can also adjust the main EQ before saving the WaveMap. Any adjustments you make will be included in the WaveMap's Baseline when you save it. This could be useful if you've trained but aren't sure it's going to suffice without a little EQ. This will allow you to conveniently answer that question.

Helpful Tip: Name your new WaveMap something simple that you'll remember later. You can more easily edit the name to something more descriptive via the web interface.

Record/Playback

Record/Playback Mode allows you to record your instrument for up to 90 seconds, and then play it back in a repeating loop.

This is useful for making Tone Shaping or EQ adjustments while hearing just the PA or amp, without the direct sound radiating from your instrument.

It works for single or dual source configurations, with full control of all parameters including blend during playback.

Hold Mute to enter or exit Record/Playback mode.

Tap Mute to start or pause recording.

Tap Boost to start or pause playback. The loop will repeat when it reaches the end of the recorded material.

Tap Mute while playing back to punch-in to recording at the cursor.

The green cursor shows the playback location.

The red cursor shows the extent of the record buffer.

Note: Recorded material is volatile and will be erased if the unit is powered down.

Important note: This is not a substitute for a performance looper, as seamless loops are not possible, nor is layering of live sound with the recorded material.

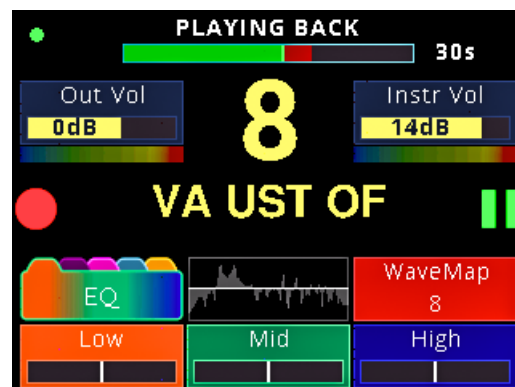
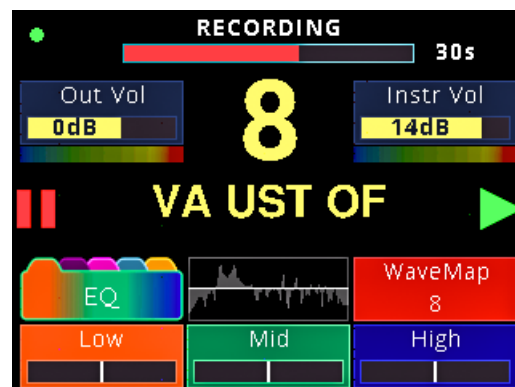
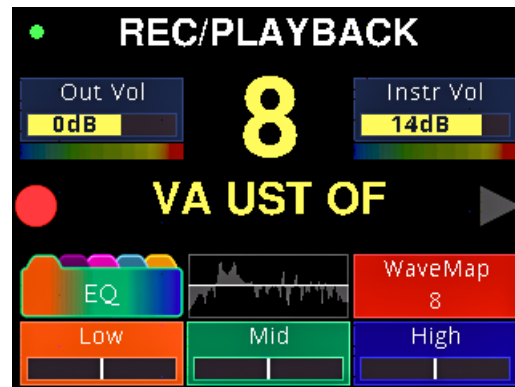

Configuration Controls

Main Page – Inputs

Tap the upper right knob to select the Inputs page. Note that this knob will be labeled dynamically, depending on which inputs are selected. You may see things like Instr Vol, Instr/Aux1, or Aux1/Aux2 for example.

Tap Main to toggle through the input choices for the main (IR) channel

- Instr
- Aux 1
- Aux 2

Tap Blend Source to toggle through input choices for the blend (dry) channel

- Instr Dry
- Aux 1
- Aux 2
- Mic

The labels above the meter bars will light to indicate which are active.

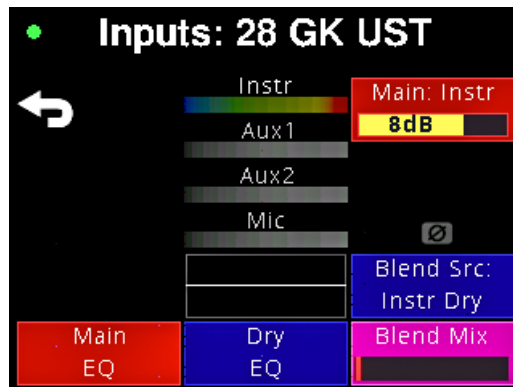

Long press the Blend Source button to invert the polarity, indicated by the blue phase symbol. 

Tap Blend Mix to select how much of the blend channel to mix into the main channel.

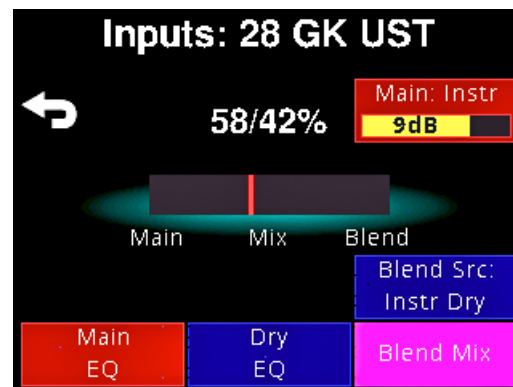

Hold Blend to invert the polarity of the blend channel. The blue phase symbol will light.

If Aux 2 and/or Mic is selected, you can engage 9V and/or 48V power by tapping or scrolling to select which, then tapping to enable.

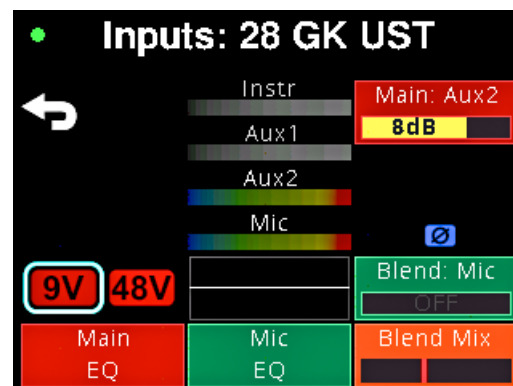

Main Page – Outputs

Tap **Out Vol** to select the Outputs page.

Turn **Out Vol** or **Aux/Phones** to set their levels.

Tap **Out Vol** again to change the phase (polarity) of all the outputs. This can be a good first step in fighting feedback on stage. The phase symbol will turn blue.

Helpful Tip: Even with headphones, one polarity position or the other will sound like it has more bass. Use whichever sounds best, keeping in mind that the position that gives minimum feedback on stage is impossible to predict, so try them both.

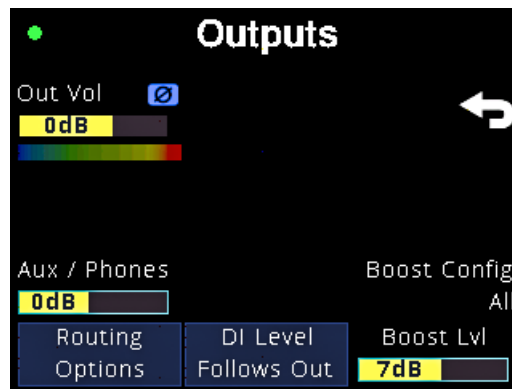

Out and DI source options

- FX Return Mono (default)
- FX Return Left
- FX Return Right
- FX Send Mono
- FX Send Left
- FX Send Right
- FX Return Left + FX Send Right
- FX Send Left + FX Return Right

Aux source options

- FX Return Mono (default)
- FX Return Stereo
- FX Send Mono
- FX Send Stereo
- Raw Pickup / Raw Mic—useful if you want to record the training session, for example

Helpful Tip: Aux Out is normally used to drive headphones but could also be used as a separate line level stereo feed to a mixer or recorder using a stereo TRS cable.

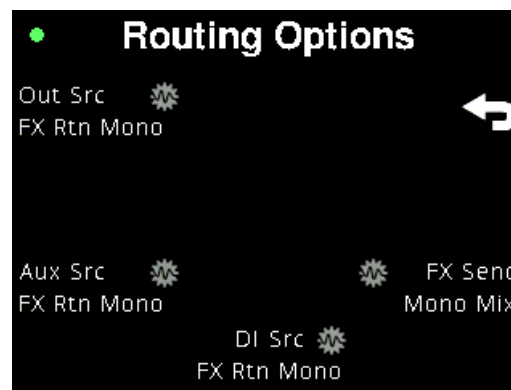

FX Send source options

Please refer to the Signal Routing Diagram.

- Mono: Mix (default)
- Stereo: Left = Main, Right = Blend
- Stereo: Left = Main, Right = Mix
- Stereo: Left = Mix, Right = Blend

The FX Sends are *half-normalled* to the FX Returns, meaning internally connected to the FX Return signals unless a cable is inserted in the FX Return jack. Plugging into the FX Output jack does not break the internal connection, so the FX outputs can be used as a separate output which stays active during mute and is not affected by the boost control.

Signal Routing Diagram

Blend Modes

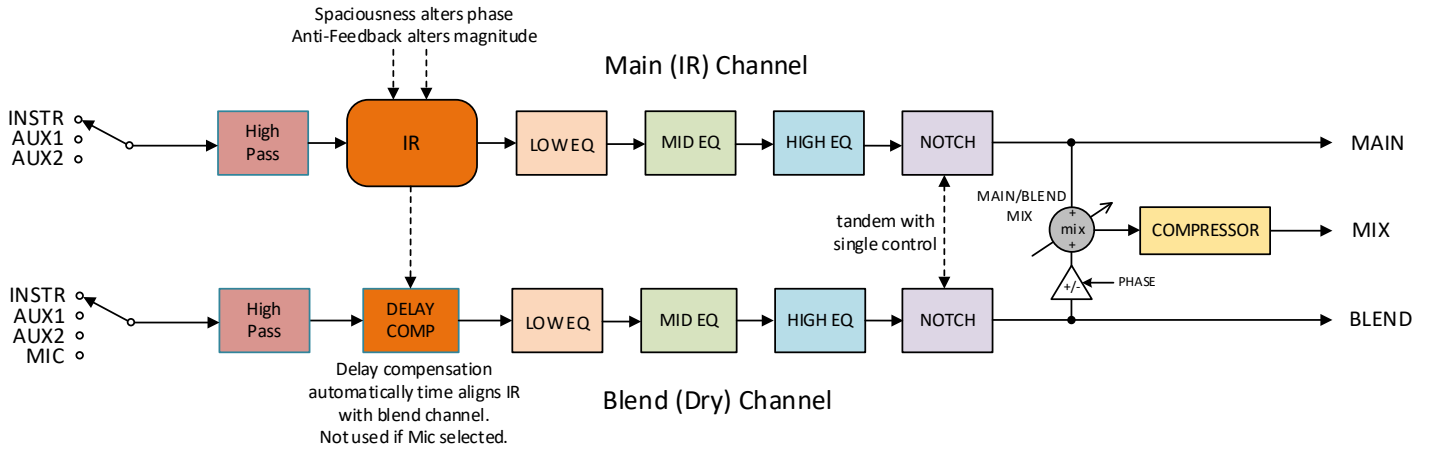

Crossover Modes

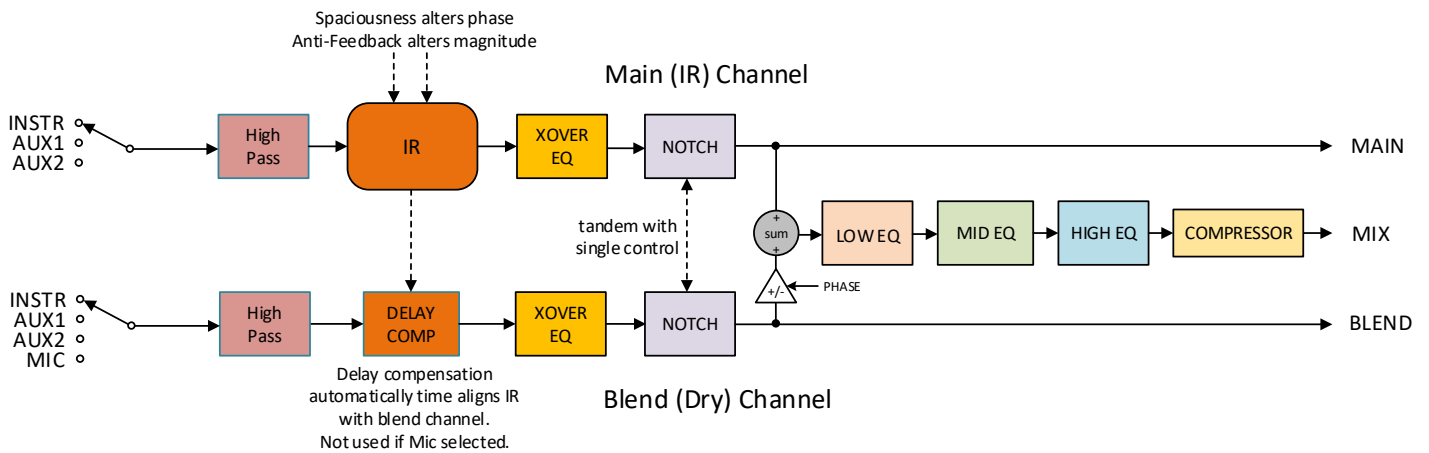

Main Page – Feature Tabs

Tap or scroll to select one of the 5 feature tabs.

EQ Tab

High pass filter

- 2nd order 12dB/octave
- 20Hz - 180Hz

High pass area shown with red shading

Low band filter

- 2nd order, select bell or low shelf
- ± 12 dB
- 20Hz – 500Hz

Low band area shown with orange shading

Mid band filter

- 2nd order bell
- ± 12 dB
- 200Hz – 8kHz
- 0.2 to 6.0 octaves width

Mid band area shown with green shading

High band filter

- 2nd order, select bell or high shelf
- ± 12 dB
- 3.0kHz – 15.0kHz

High band area shown with blue shading

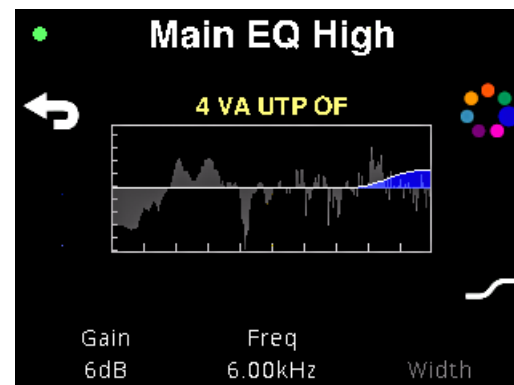
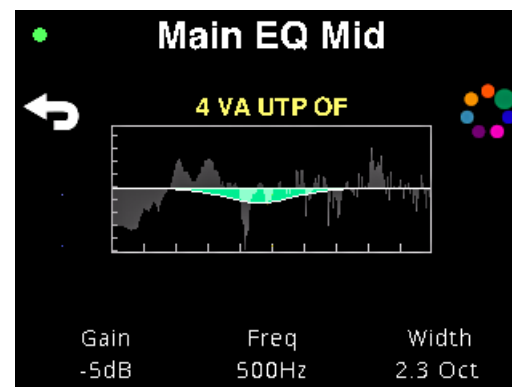
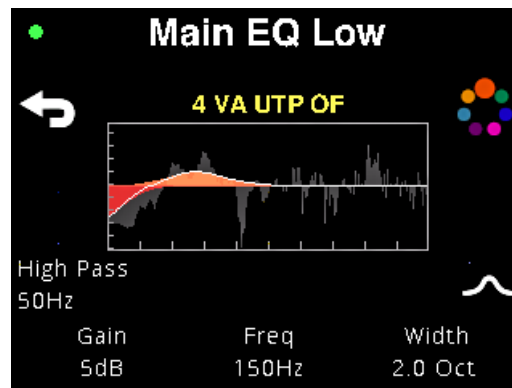

Anti-Feedback

Acoustic body instruments have natural resonances. The strongest of them are frequencies that can cause feedback problems, and are usually at the low end of the instrument's frequency range. These resonances show as peaks in the WaveMap frequency response graph due to the mic hearing them during training. ToneDexter II allows the user to reduce them without having to know exactly what frequencies they are. It is normal to have large peaks and dips. This is a large part of what makes an acoustic instrument pickup sound rich and interesting.

Helpful Tip: *The response graph does not exactly represent what your ear is hearing, as it is not taking into account what the pickup is sensing from the strings and instrument's body. It just represents the difference between your pickup and what the mic heard during training. The horizontal ticks are notes A0 (27.5Hz) through A9 (14.08kHz). Vertical ticks are every 5dB.*

Adjust Anti-Feedback from 0% to 100% to reduce any response peaks that are lower than the top frequency. Reduction starts at the tops of the peaks and continues down. 100% brings them down to about 0dB.

Adjust Anti-Feedback amount from 100% to 200% to further dip the peaks below 0dB.

Adjust Top Freq to encompass the peaks you want to attenuate, up to 500Hz. The **blue section** indicates the active region.

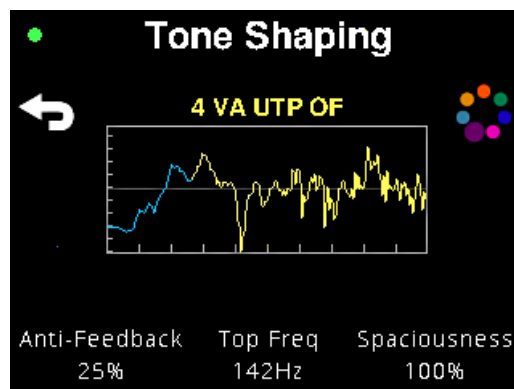

Spaciousness

Acoustic body instruments act like miniature echo chambers and the vibrations can last as long as 20-30ms or more. This is especially true of upright basses where the time spread is usually much longer than a guitar. The WaveMap IR creation process captures this time information, and it can be shortened or lengthened with the Spaciousness control.

Helpful Tip: This alteration does not change the frequency response or tonality. The spaciousness and Anti-Feedback controls are completely independent. For the technically minded, Spaciousness adjusts the phase (and time) while Anti-Feedback adjusts the magnitude.

As you reduce Spaciousness from 100% towards 0%, the sound becomes more immediate and direct, without changing its timbre. This is useful in live situations where room acoustics are obscuring the nuance of your acoustic sound and you need to cut through better.

As you **increase Spaciousness** from 100% towards 200%, you lengthen the subtle echoes and delays in your acoustic sound. This can be useful in recording situations to increase perceived richness.

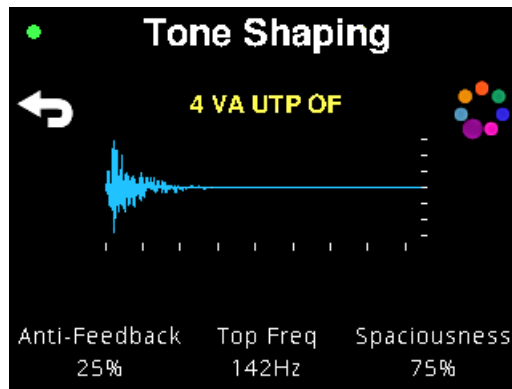

Notch Tab

Notch filter

- 2nd order Peaking EQ
- 0-24dB depth
- 1-10 semitones width

Notch filter area shown with violet shading

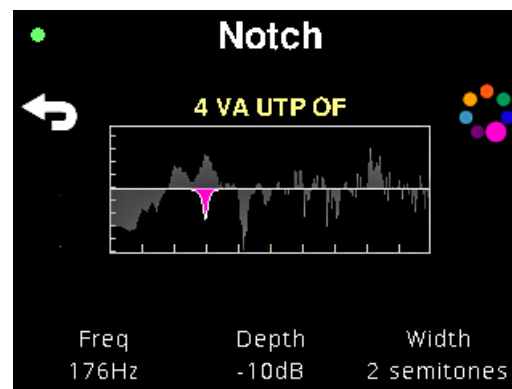

Helpful Tip: On any page, the circle of dots shows you where you are. By tapping or scrolling that button, you can quickly move from one adjust page to the next.

Reverb Tab

Level

Adjust to add reverb. 0% is fully dry, with no reverb. 100% is fully wet with no dry signal.

Type

- Plate 1 small – default
- Plate 2 large
- Room 1 small
- Room 2 large
- Hall 1 small
- Hall 2 large

Destination

- FX Loop + Aux – default
- FX Loop only
- Aux only

Source

- Mono Mix – default
- Main Channel
- Blend Channel

Sprocket

Reverb settings are by default global. **Tap the sprocket** to make the reverb settings WaveMap-specific rather than global. It will turn gold to indicate it is WaveMap-specific

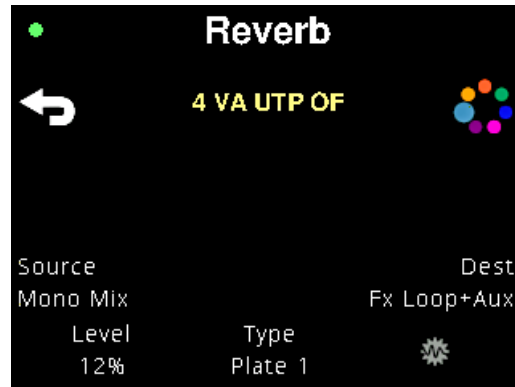

Reverb Routing Diagram

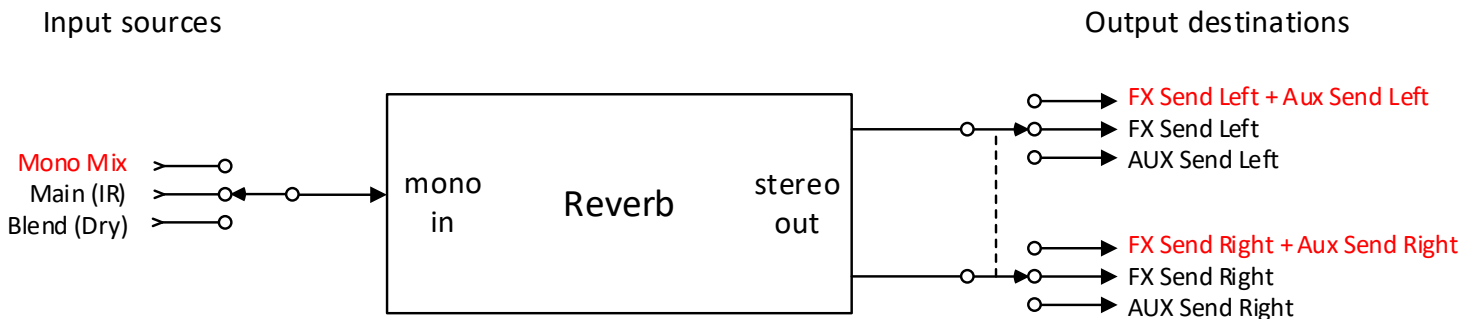

Defaults shown red

Compressor Tab

Compressor controls can be intimidating, so this compressor is designed to be simple to use. It's a one-knob compressor that smartly adjusts parameters automatically as the Amount knob is turned.

Amount

Turn this clockwise to increase the amount of compression from none to a lot. As you adjust the knob, you can see the changing threshold indicated by the vertical red line. The ratio is indicated by the slope of the line above the threshold.

Makeup gain is automatically added to keep the loudness level about the same at any setting.

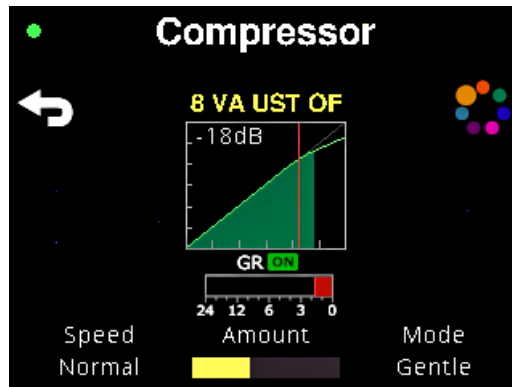

The compressor has a soft knee for transparent operation.

Note: Compressor settings are always WaveMap specific, there is no global setting.

Helpful Hint: the actual threshold level will show in the graph if you have selected **System Config -> Display Settings -> Gain Values: Show**

Speed

Select Normal to increase the apparent sustain of fast decaying instruments. **Select Slow** to control the level of what you're playing over a longer time span. This is useful to control the output level without adding sustain.

Mode

Select Gentle for the most transparent compression. **Select Strong** for a more aggressively compressed sound.

GR

The Gain Reduction meter shows how much compression is happening, showing actual gain reduction in dBs. While you play, you can watch this meter—along with the graph above—to know when you're engaging the compressor action.

The sound of compression can be subtle, and that's usually a good thing. To hear the contrast between the compressed and the dry signal, **tap Amount** to toggle the compressor on and off. The green ON symbol will indicate the state. You can also turn the compressor on and off from the main page by **holding Amount**.

Main Page – WaveMap

Tap the **WaveMap** button to enter the WaveMap page. From here you can rename, delete, adjust trim gain, manage and resave your WaveMaps.

Tap the **pencil symbol** to rename your WaveMap.

Tap **Revert to Saved** to set the active parameters back to the Baseline parameters.

Tap the **trashcan symbol** to delete the current WaveMap. You will be asked to confirm the delete, or cancel.

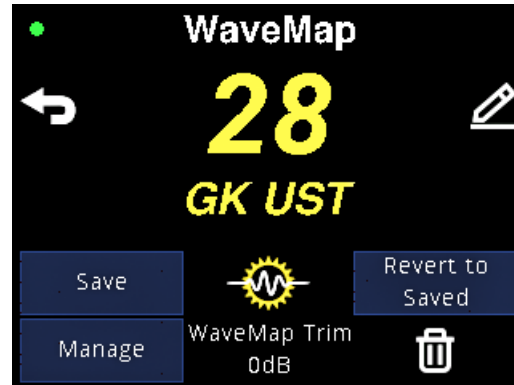

Turn the **WaveMap Trim control** to adjust the level up or down by as much as 6dB. This is independent of the input or output gain settings and can be used to match the WaveMap loudness to the bypassed loudness. It is also useful for adjusting WaveMaps before baking.

Tap **WaveMap Trim** to toggle the IR processing on and off. This is useful for auditioning when trying to match the loudness of the signal with no IR to the loudness with the IR.

Tap **Save** if you're happy with your sound and want to save the current configuration to the WaveMap's Baseline, which can then be recalled at any time, allowing you to further adjust and tweak.

Rename WaveMap

Turn **Cursor** to move the underlined character focus, **turn Char** to select a character.

Tap **Space** to insert a space.

Tap **Char** as a shortcut to advance to the next character location.

Tap **ABC** or **Hold Char** as a shortcut to toggle between upper case, lower case, and numbers/symbols.

Hold to Save to commit the name change.

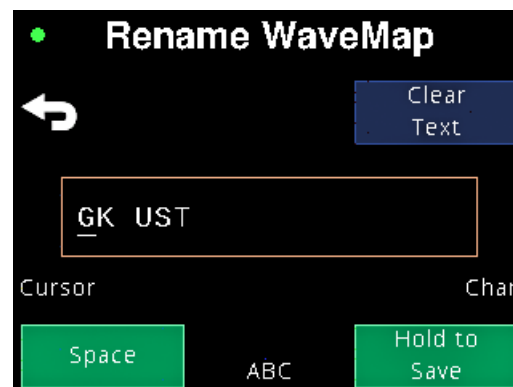

Helpful Tip: Renaming, copying, and moving WaveMaps can also be done, more conveniently, by using the WaveMap Management web interface.

Manage WaveMap

Tap **Manage** to bring up the Manage WaveMap page.

In large numbers you'll see the current WaveMap and an arrow pointing to the next open slot. **Turn the Sprocket** to select another destination.

Tap the **Copy Icon**  to overwrite the data at the destination slot.

Tap the **Move Icon**  to move to the destination slot. The other WaveMaps will shuffle over to make room.

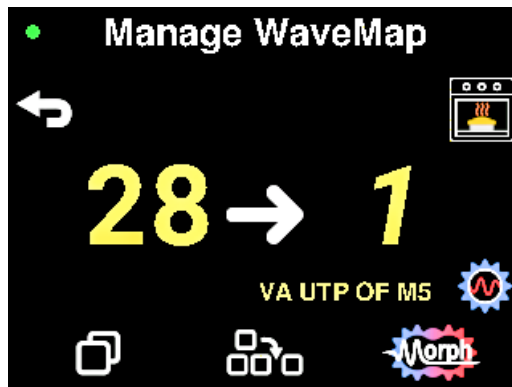

Baking WaveMaps

Tap the **Oven Icon** to bake a WaveMap.



Baking a WaveMap makes a copy of the WaveMap that incorporates all EQ, Anti-Feedback, Spaciousness and Trim settings into a new WaveMap in which those settings are baked in, as if it had been created that way from the start.

This resets all adjustment parameters and allows them to be redeployed anew on the baked WaveMap. This is useful for tweaking them to your liking and committing to them, thus freeing up the EQ and Tone Shaping tools to deal with venue specific adjustments rather than WaveMap corrections. It's also useful for creating WaveMaps tailored to other target pickups when using solid body instruments.

Helpful Tip: *Baking a WaveMap always makes a copy, leaving the original unaltered. A 'B' is appended to the name to remind you, but you can always rename them. A WaveMap can be baked with variations as many times as you like. A baked WaveMap can even be re-baked, creating a biscotti 😊.*

Morphing WaveMaps

Morphing two WaveMaps combines the sound of one WaveMap with another to create a 3rd WaveMap with a sound that is somewhere between the two. This is useful when training WaveMaps from two distinct mic positions and then morphing to achieve a sound that is a cross between the two. Unlike mixing two mics together ahead of training, there will be no phasing issues with this method. In the example shown here, one mic was at the 12th fret, the other down below looking up at the sound hole.

Tap the Morph symbol to enter the Morph page. The title shows the WaveMap position from which you entered the morph function. This is the source WaveMap.

Adjust the Top Sprocket to select the target WaveMap you want to morph with.
Adjust Morph to select the morph mixture between the source and target. 0% means all source. 100% means all target.
Blue trace shows the source response.
Red trace shows the morphed response and changes from source to target as you adjust the morph mix from 0 to 100%.

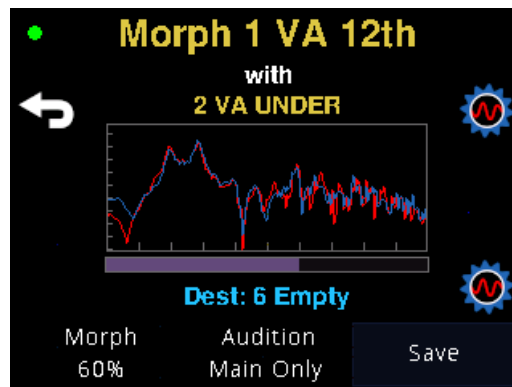

Tap or Turn Audition to select what you are hearing:

- Main Only: Including any effects or EQ, but without the Blend channel
- All: Main and Blend channel mix including any effects or EQ.
- IR Only: Just the raw IR processing with no effects or channel processing.

Adjust the Lower Sprocket to choose a destination for the morphed result.

Tap Save to create the morph.

System Config Settings

Tap **Boost**, then **System Config** to access various option pages

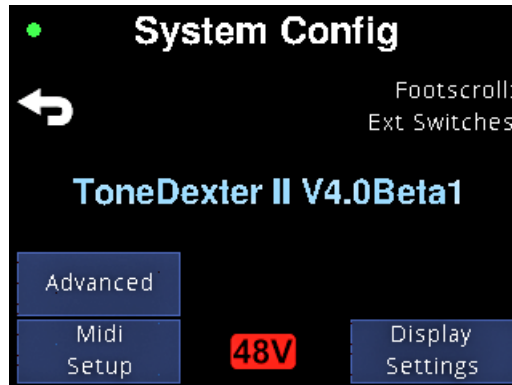

Footscroll

Select **Ext Switches** or **Integral** to control which set of switches Footscroll and Screenlock are assigned to, according to this table.

| Selection | Mute/Boost | Footscroll | Screenlock |
|---------------|-------------|------------|------------|
| Ext Switches: | Int | Ext | Int |
| Integral: | Int and Ext | Int | Ext |

If Integral is selected, you can change the behavior to match how the original ToneDexter used to work. The up and down arrows are now both on the right-hand side indicating the original ToneDexter behavior.

- Tap Mute: Toggle into and out of the Tuner
- Tap Boost: Increment the WaveMap Number
- Hold Mute: Leave Footscroll mode
- Hold Boost: Decrement the WaveMap Number

In Footscroll mode, you'll see up and down arrows on either side of the WaveMap name. This allows convenient changing of the WaveMap selection without having to turn the WaveMap knob.

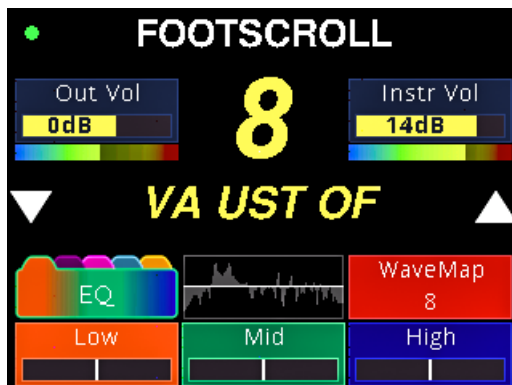

Screenlock

In Screenlock mode, you'll see a lock symbol in the upper right corner. Screenlock mode will prevent any controls from affecting the WaveMap in use, other than Mute and Boost.

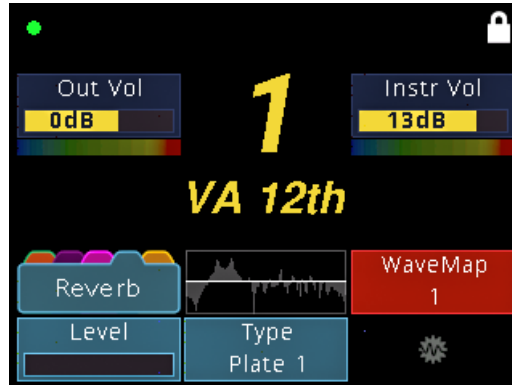

Display Settings

Start In

ToneDexter starts up in Play mode by default. You can change it to start in Tune mode with the main and DI outputs muted.

Gain Values

Default is Hide. **Select Show** to add a numerical gain figure to the level bar indicators.

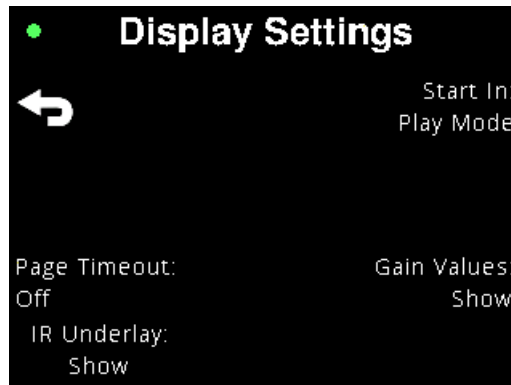

IR Underlay

You can view the Frequency Response Plot of the WaveMap on the main page by changing IR Underlay to Show. This adds a grey plot of the IR response behind the EQ curve, which may be useful for comparing WaveMaps at the expense of a little extra clutter.

Page Timeout

The pages reached by tapping a control (such as an EQ band adjust or Inputs) will time out and return to the Main page after a few seconds of inactivity. This is useful if you wanted to make a change while at a gig, then stand back up and continue playing without having to push the Back button.

However, you may want to stay on one of those pages for longer, especially if you're new to ToneDexter and are wondering what to do next. In those cases, set the Page Timeout to a higher value, up to 20 seconds. If you keep going past 20 it turns the timeout off altogether and you will have to push the Back button to return to the previous page.

48V

Tap to toggle the 48V mic bias on and off. This can also be controlled from the Training page.

MIDI Setup

You can choose a WaveMap using Program Change commands via the MIDI interface. The control select switch on the rear needs to be set to MIDI, then plug in any MIDI controller via a standard TRS Type A MIDI cable.

- You can configure ToneDexter to respond to all MIDI channels (default) or select a channel from 1 to 16.
- Any Program Change (PC) number (0-127) can be configured to change to any WaveMap slot (1-32).
- Default mapping is
 - PC[0] maps to WaveMap 1
 - PC[1] to WaveMap 2, etc, repeating such that
 - PC[32] is back to WaveMap 1 again, and so on.
- Choose a PC number and then update which WaveMap it points to. It saves automatically when leaving the MIDI setup page.
- If your MIDI controller sends Control Change (CC) messages instead of Program Change, you can use the Bank Select (command 0). The data value (0-127) then maps to WaveMap slots using the same mapping as Program Changes.
- Output Volume can be controlled by Control Change 7 (Volume).

Advanced

IR Import

Optimized is the default. 3rd party IRs are improved with ToneDexter processing for the best experience. Select Unaltered to import them unchanged.

Mute Hold

Selects which function is associated with a hold to Mute. Default is Bypass mode. Select Rec/Playback to enable that feature in lieu of Bypass.

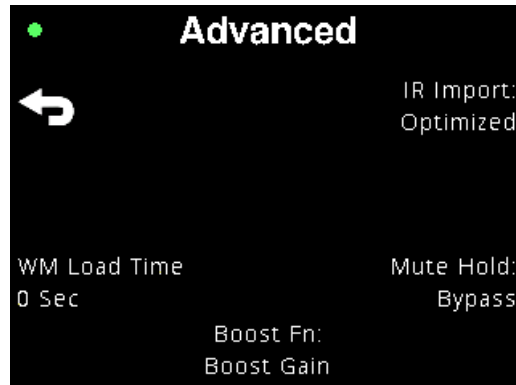

Boost Function

Selects which parameters are associated with the Boost function.

- Boost Gain
- Toggle Reverb
- Gain + Reverb

WM Load Time

Depending on your instruments and how you use them, you may be connecting different instruments with wildly different levels that need much more or less gain. In those cases, selecting the wrong WaveMap could cause a large jump in signal level, which could potentially cause roaring feedback as you scroll through.

If you're worried this might happen to you, increase the WM Load Time to anywhere from 0.5 second up to 2 seconds. This will allow you to see which WaveMap you're about to load before you load it, and you can scroll past high gain WaveMaps without them loading.

Helpful Tip: *The WM Load Time setting affects the Main page only. The load time is fixed at 0.5 second while on the Tuner page, to give you time to read what WaveMap you've just selected without obscuring the Tuner display for too long. WaveMaps always load immediately if you are on a different page like Inputs, EQ, or Tone Shaping (note you can only change WaveMaps using external footswitches or Footscroll mode while on these pages).*

Active and Baseline Memory

Any time you adjust EQ, Tone Shaping, or Input source parameters, the change is automatically saved with the Active WaveMap memory—you don't have to think about it or do anything. When that WaveMap is recalled, the parameters will be recalled exactly as you left them, even after powering down and back up.

If you're happy with the sound and want to save the active parameter settings in the Baseline Memory, Hold WaveMap (or tap WaveMap then Save). This will copy all Parameters to the Baseline Memory for the current WaveMap.

You are now free to make new changes to, say, tailor your sound for a particular venue, and can revert to the Baseline configuration at any time, which may be a better starting point for the next venue.

To recap: changed parameters are automatically stored in the Active Memory without having to take any action. Baseline settings are those that were deliberately saved. You can recall the baseline settings by tapping the WaveMap control, then tapping Revert to Saved.

Using the Web Interface

- Connect ToneDexter II to your computer, either Mac or PC, using the provided USB cable.

Helpful Tip: Some USB cables supplied with toys or other non-technical devices only have the power pins connected, as they are only used to charge the device's internal battery. If you use a different cable other than the one supplied, make sure it is a data cable.

- Go to your favorite browser and type in the URL 192.168.7.1
- The Web Management tool should appear. It is a live link to your ToneDexter II, and not to an external site.
- Save that as a bookmark for future reference.



Managing WaveMaps

 Click and drag a WaveMap to another location to reorder your set.

 Copy WaveMap creates a clone in the next available slot. Appends C to the name.

 Save to Baseline only applies to WaveMaps with italicized names, indicating there have been adjustments to the WaveMap in active memory that haven't been saved to baseline memory. Use this if you want to save those active parameter adjustments to the baseline memory.

 Edit the name

 Saves the WaveMap to a name.wm file.

Helpful Tip: The file saved includes the WaveMap's Baseline parameters but not any adjusted parameters that haven't been saved to the Baseline. The web interface will warn you before saving a file that has parameters in active memory that haven't been save to Baseline memory.

 Deletes the WaveMap

Helpful Tip: Changes that are made on the web interface, such as naming or reordering a WaveMap, will instantly take effect and be permanently saved on your ToneDexter II.

 Import WaveMap from a WaveMap *name.wm* file, or from a 3rd party IR *name.wav* file.

3rd Party IRs: In addition to *name.wm* files, ToneDexter II supports importing 3rd party Impulse Responses, as well as original ToneDexter *number.wm* files. Supported import formats are Legacy WaveMaps created with the original ToneDexter using general, high, or bass firmware. 3rd party IRs must be 16bit, 24bit, 32bit, or 32bit floating point mono WAV files at a sampling rate of 30kHz to 50kHz, and be 64KB or less in size. They will be truncated to 4096 samples if greater than that.

By default, 3rd party IRs are optimized and improved for use in ToneDexter II. There is an option in System Config → Advanced Options to select IR Import Optimized or Unaltered.

Color and Text Meaning

Gold text (or **Red slots** on the web interface) indicates the slot contains a trained WaveMap.

Blue text (or blue slots) indicates the slot does not contain a trained WaveMap, but has had other parameters adjusted such as gains, EQ, or routing configuration. These would typically be used for a dual source configuration with blending or crossover, or instruments for which training wasn't required.

Gray text (or gray slots) indicates unused (empty) slots. Changing any gain, EQ or routing parameter will turn it Blue.

Red text occurs when a 3rd party IR is imported with an unsupported format. Simply erase this slot or overwrite it.

Italics indicate that adjustments have been made to the WaveMap since it was last saved as a Baseline. More about Active and Baseline memory in the Parameter Adjustment section below.

Straight text indicates the WaveMap is in its Baseline configuration.

Backup Button

Writes all existing into a *wavemap_set_name.bak* file. The front part of the file name should be changed to something meaningful.

Restore Button

Reloads WaveMaps from a selected *wavemap_set_name.bak* file.

Help Button

Allows easy access to online resources.

Updating Software

ToneDexter will automatically check for new updates for registered units whenever you connect to the Web Interface, provided you are connected to the Internet. Click Download and Install and the latest version will be automatically loaded. From V2.6 onwards, you will need to register your unit with Audio Sprockets through the web interface before you can receive software updates. Your personal information will not be shared outside of Audio Sprockets, and you will be given the option to opt out of receiving email messages if you prefer.

It is strongly recommended that you make a backup of your WaveMaps before starting the software update procedure.

Updating from Versions Before V2.3

- If you currently have a version lower than V2.3 and want to update, you will need to load the V2.8 binary file manually first.

Helpful Tip: *The current version of software is displayed on the screen as it starts up, and for later versions appears in the footer of the Web Interface as well.*

- Save V2.8 software binary (it will be of the form *filename.bin*) from the [Audio Sprockets website software download page](#) to your download folder, or any other convenient location.

Helpful Tip: *If your computer complains about not knowing what to do with a .bin file, don't worry, you're just saving it to your hard drive, not running it.*

- Click the Software Update button on the web interface and browse to the *filename.bin* file you just saved.
- Click open or okay at the prompt, then the red upload button and ToneDexter II will be updated.

Recovery method

Always try the Normal Method first, but if for some reason the software update fails and the screen goes black, use this recovery method to restore and update the unit using a *filename.uf2* file instead of the *filename.bin* file.

- Connect a USB cable and the power supply.
- Press and hold the red boot button on the rear for 1-2 seconds and let go. A removable drive named RPI-RP2 or NO NAME will appear on your computer.
- Drag (or copy and paste) the *filename.uf2* file to this drive. Say OK to any warnings. The removable drive will disappear once transfer is complete. Ignore the eject warning.

Integrating a Looper

Live

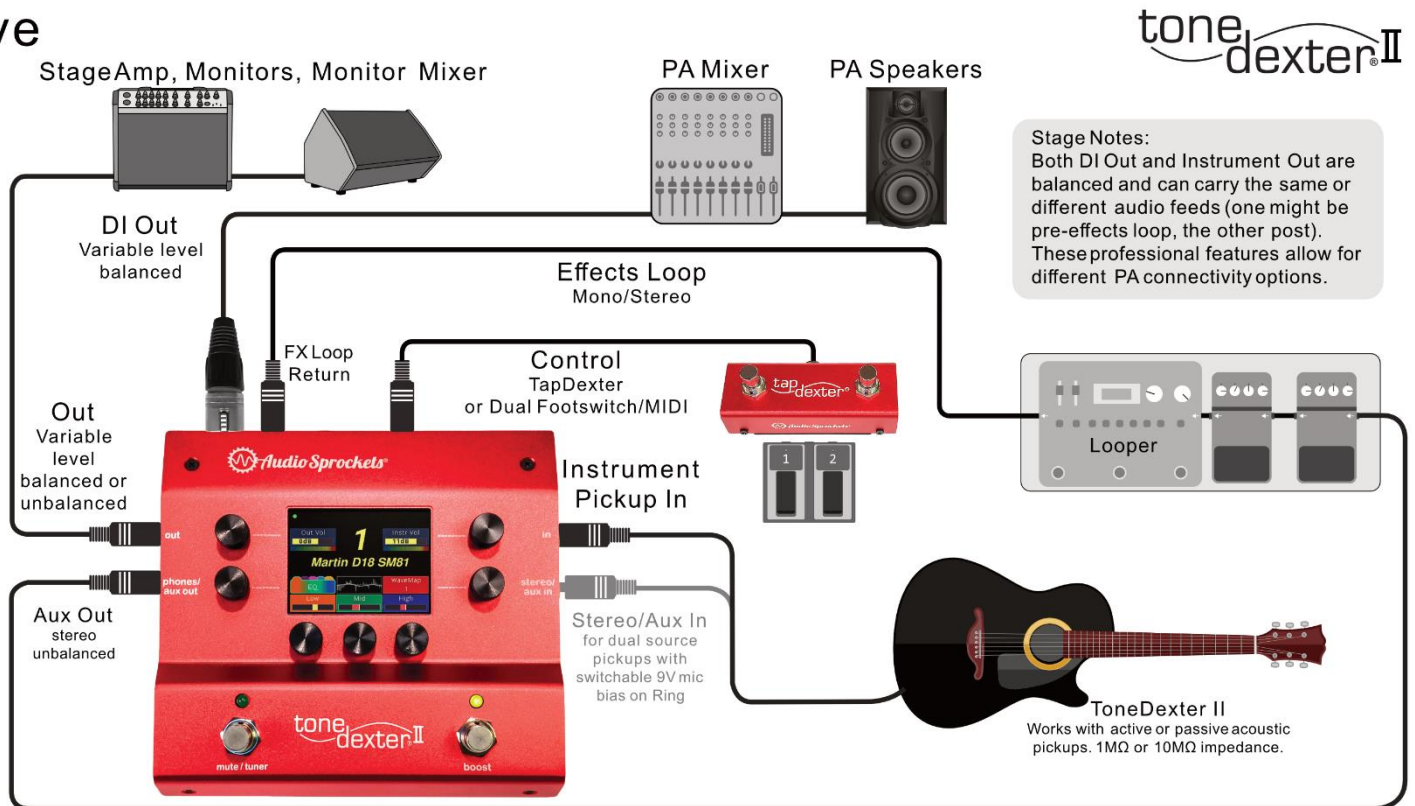

You will most likely want to put your looper in the FX loop, configured to either the default mono mode or as part of a stereo or dual FX chain. However, be aware that the FX Send output cannot respond to a Boost press. It is fixed level.

If your Out and DI outputs are set to the default where they are affected by Boost, this means that the output of your FX chain with looper will be boosted. This includes any loop that may be playing, as well as the instrument feeding the looper and FX chain. This may not be optimum.

If you want the instrument to be boosted for soloing, but you want the loop to stay at constant volume, there is an alternative configuration that will provide this:

- Feed your FX chain from Aux out instead of FX Send.
- Set Boost Config to Aux Only

This way the FX return signal(s) that feed Out and DI will not be boosted, but the instrument signal feeding Aux out to your effects chain will be boosted.

Troubleshooting Info

This section lists the most common issues you may have and the remedies.

No sound

If you are plugged in but getting no sound from the outputs:

Make sure the input and output gains are not turned all the way down. You should see activity on the level meters.

Make sure you haven't selected an input source that you are not plugged into, such as Aux1 when you are plugged into Instr. See the Input Source Modes section.

Make sure you haven't selected the output source to be the right channel only but have no dry blend or dual source feeding the right channel. See the OUT, DI, and AUX source option diagrams.

Hum

If you are using a passive piezo pickup, you may hear some AC power line buzz or hum if your system is not grounded. In normal use, ToneDexter II will be connected to an amplifier or PA system, which is grounded (earthed), and you will not experience any noticeable hum.

But if you do experience hum in your headphones when training, plugging one of the other outputs into a grounded system will eliminate it.

Screen going white or continuously resets at startup

The power supply you are using is likely under-powered, see A Word About Power Supplies.

WaveMap loading, backups and software updates not working

For versions prior to V2.0 there were issues with sending data to the ToneDexter using the Safari web browser. Backups and WaveMaps saved in previous versions will load with the V2.0 or higher with no problems.

Manage WaveMaps on the Web Interface stuck on 'loading...'

The most likely cause is an attempt to load a WaveMap in a slot that was corrupted by using Safari. Delete that WaveMap from the WaveMap page on the unit itself, then reload your WaveMap once you've upgraded the software to version V2.0 or higher.

I can't get into/out of Tune when using integral Footscroll mode

In Integral Footscroll mode, the Mute button is used to scroll down through WaveMaps. Getting into and out of Tune mode is achieved with a Hold of Mute instead.

Web Interface is not loading or has stopped responding

Make sure you're using a USB data cable like the one supplied with the ToneDexter II, and not a charging-only cable.

If you normally see the web Interface but it has stopped responding, try unplugging and reconnecting the USB cable, or resetting the ToneDexter by tapping the red boot button on the rear panel. You may then need to refresh/reload the page.

Note that after a software update, the ToneDexter resets and so will disconnect the web interface. The page should reload automatically a few seconds after reboot is complete.

Factory Reset

If for some reason you want to totally remove all data, you can perform a factory reset. Be aware that all WaveMap data will be deleted, so back them up first by connecting to the web management page and hitting the Backup button. Save the *name.bak* file to a convenient location.

Tap the red button on the rear to restart the unit then press and **press both the Aux In and Aux Out buttons simultaneously and hold** while the spinning sprocket is displayed on startup.

This will give you the option to confirm a factory reset or cancel.

Select Fast to eliminate all the WaveMaps and associated data.

Select Full to totally erase the memory. This would only be necessary under highly unusual circumstances.

Pro Tips

- To **easily see differences** between WaveMaps for any of the Tab parameters like EQ, Anti-Feedback, etc., select what you want to see, then use Footscroll to move between WaveMaps. The screen will continue to display the desired parameter as it changes from WaveMap to WaveMap. You can do this with external footswitches, or with the internal ones if Footscroll mode is set to Integral and you engage Footscroll mode with a long press to Boost.
- **Do take advantage** of the record/playback feature, as it is revelatory in assessing what the audience will hear since you won't be hearing direct sound radiating from your instrument mixed in. Plus, you won't be busy playing, so you can concentrate more on listening for any adjustments you need to make.

- Your ear's sensitivity to midrange frequencies is stronger than it is to lows and highs. When playing through a loud PA in particular, try a broad reduction of the mid-frequency gain to keep the instrument sounding natural.

System Diagram

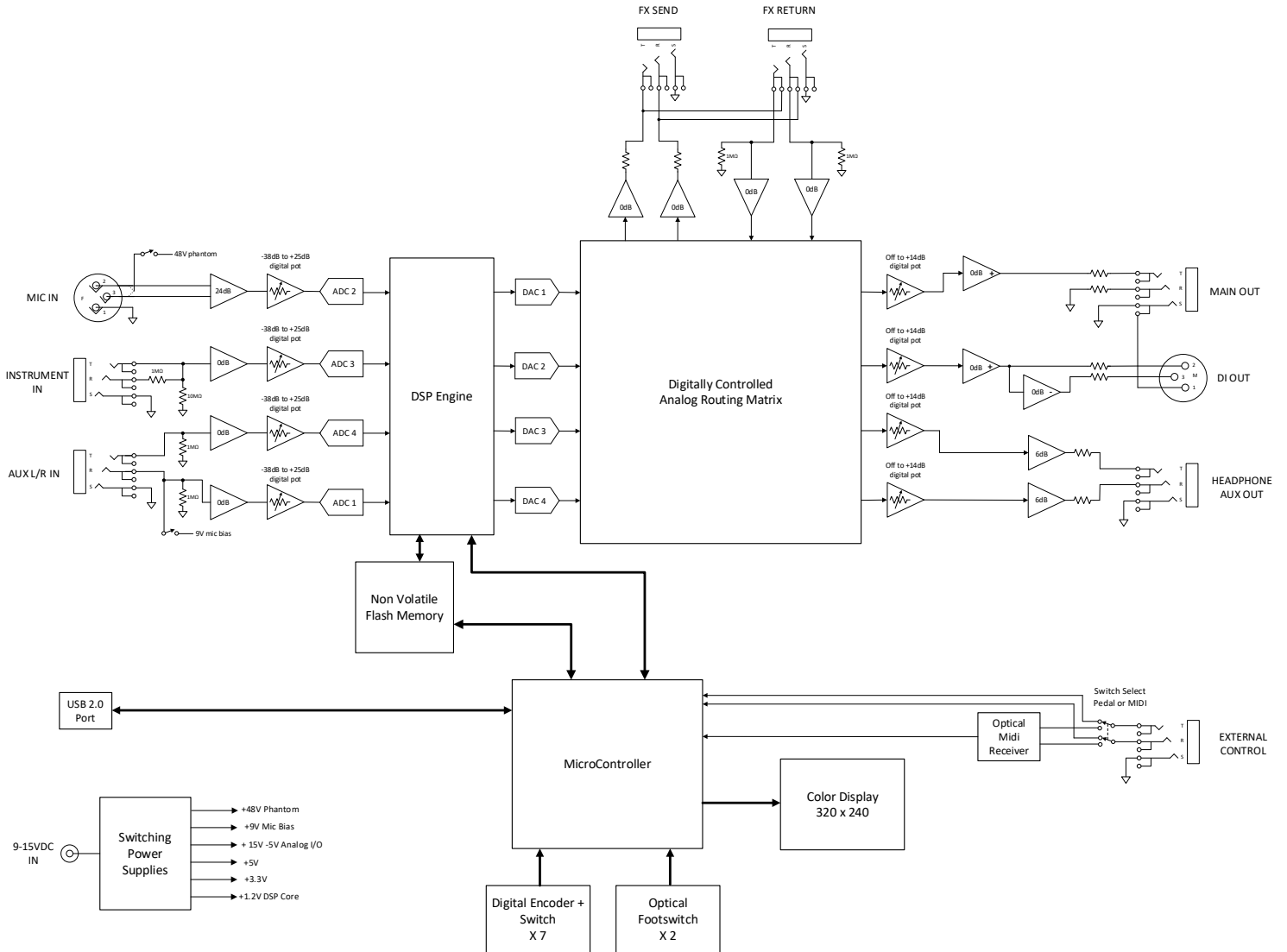

Technical Specs

Instrument Input (in)

- 1/4" phone jack
- Input impedance: 1MΩ if using a standard mono plug, 10MΩ if using a TRS plug with RING unconnected
- Gain range: -38dB to +25dB
- Max signal level before clip: +9dBVrms

Aux Input- Aux1 (TIP) and Aux2 (RING)

- ¼" TRS phone jack
- Input impedance: 1MΩ
- Gain range: -38dB to +25dB
- Maximum signal level before clipping: +9dBVrms
- If +9V bias enabled, 10kΩ on RING

Mic Input

- XLR female
- Input impedance: 2kΩ differential
- Gain range: -11dB to +49dB
- Maximum signal level before clipping: +9dBVrms
- Switchable +48V phantom power

Main Output

- 1/4" TRS phone jack
- Unbalanced single ended, or impedance balanced differential drive
- Source impedance: 300Ω per side
- Gain range: off, -34dB to +14dB
- Max signal level before clip: +9dBVrms

DI Output

- 1/4" TRS phone jack
- Voltage and impedance balanced differential drive
- Source impedance: 300Ω per side
- Gain range: off, -28dB to +20dB
- Max signal level before clip: +15dBVrms differential

Aux Output

- 1/4" TRS phone jack
- Dual mono or stereo operation, capable of driving most headphones
- Source impedance: 20Ω per side
- Gain range: -22dB to +26dB
- Max signal level before clip: +9dBVrms differential

FX Send

- 1/4" TRS phone jack
- Dual mono or stereo operation
- Source impedance: 500Ω per side
- Max signal level before clip: +9dBVrms

FX Return

- 1/4" TRS phone jack
- Dual mono or stereo operation
- Input impedance: 1MΩ per side
- Max signal level before clip: +9dBVrms

USB Jack

- USB 2.0 - either USB-micro or USB-C depending on serial number

DC Power Input

- 2.1mm pin, 5.5mm barrel
- Accepts 9-15VDC, either polarity

Control Jack

- 1/4" TRS phone jack
- If MIDI selected, optically isolated input wired to the TRS Type A MIDI standard
- If footswitch selected, Tip and Ring are pulled up to +5V with a 20mA current source
- Connected footswitches must be momentary-type and make connection to ground when pressed.

On Board Footswitches

- Optical interrupter sensors for zero wear operation



Additional support and operational information is available on the Audio Sprockets website including:

SUPPORT - [AudioSprockets.com/support](https://www.audiosprockets.com/support)

- Frequently Asked Questions—FAQs with sections about which pickups work with ToneDexter II, power supply info and general questions about operation and training
- Software Versions - Version history, downloads and install
- Setup and Training videos
- WaveMap Transfer and Archive, info and how-to video
- Support Request Forms

